

ORDINANCE NO. _____

An ordinance amending Title 2 – Administration and Title 22 – Planning and Zoning of the Los Angeles County Code that corrects minor technical errors and discrepancies, reformats and reorganizes sections, streamlines procedures, makes the County Code consistent with State law and other County regulations, and adds definitions and clarifies code language for ease of implementation.

The Board of Supervisors of the County of Los Angeles ordains as follows:

SECTION 1. Chapter 2.108 is hereby amended to read as follows:

Chapter 2.108 – Regional Planning Commission

2.108.010 – Membership.

The regional planning commission of the county of Los Angeles shall consist of:

- A. Five members appointed by the board, ~~as provided by Section 65330 of the Government Code;~~
- B. The following advisory members, ~~as provided by Section 65331 of the Government Code:~~
 1. The director of public works;
 2. The fire chief. ~~The agricultural commissioner/director of weights and measures;~~
 3. ~~The director of parks and recreation.~~

2.108.020 – Deputies for advisory members.

~~Pursuant to Section 65128 of the Government Code,~~ Each advisory member may designate one of his deputies to sit on the regional planning commission in his absence.

2.108.030 – Term of office.

Appointment shall be for a period of four years, ~~as provided in Section 65124 of the Government Code.~~ If a vacancy occurs other than by the expiration of a term, it shall be filled by appointment for the unexpired portion of the term. The terms of the advisory members shall correspond to their respective official tenures as county officers.

....

SECTION 2. Section 22.02.070 is hereby amended to read as follows:

22.02.070 – Application Where Violation Exists.

A. ~~No~~ Unless otherwise required by State or federal law, an application required by pursuant to this Title 22 shall not be accepted for processing or approved where an existing land use, not previously authorized by any statute or ordinance, is being maintained or operated in violation of any applicable provision of this Title 22, or any condition of approval of a land use permit. This provision applies to the operation of land uses only, and does not affect buildings or structures which do not conform to development standards. on a lot where:

1. An existing land use was not previously authorized by statute, ordinance, or land use permit;

2. An existing land use, previously authorized, has had its authorization expire or otherwise be invalidated; or

3. A valid authorization exists but such authorization does not include an existing land use.

B. ~~Where in the sole discretion of~~ Notwithstanding Subsection A, above, the Director, ~~whose determination shall be final,~~ the Director determines that the use in question is consistent with the objectives, goals, and policies of the General Plan, or that the continuation of said use is essential or desirable to the public convenience or welfare, this provision shall not apply. may accept an application after determining, through the issuance of a clean hands waiver, all of the following:

1. The land use is consistent with the objectives, goals, and policies of the General Plan;

2. The land use is allowed in the underlying zone and is consistent with this Title 22, including all applicable development standards;

3. The land use was previously authorized through the issuance of a land use permit, if one was required, or is subject to a Type I Review—Ministerial (Chapter 22.226);

4. The land use in question does not adversely affect locally regulated biological, historical, or coastal resources;

5. The lot containing the land use does not have a history of documented non-compliance with this Title 22; and

6. The lot containing the land use does not have a history of documented non-compliance with other local, State, or federal laws, rules, or regulations.

C. Notwithstanding Subsections A and B, above, the Director may accept an application if, in the sole discretion of the Director, the land use is compatible with the surrounding community, including existing legally established land uses nearby. In making this determination, the Director may consider, among other factors, whether the continuation of said use is essential or desirable to the public's health, safety, or welfare.

D. The Director's determination pursuant to Subsection B or C, above, shall be final and not subject to appeal.

SECTION 3. Section 22.14.160 is hereby amended to read as follows:

22.14.160 – P.

...

Public Art in Private Development Program. The following terms are defined solely for the purpose of Section 22.246.090 (Public Art in Private Development Program):

...

Alteration. Any construction or renovation to an existing structure other than repair or addition. A change, addition, or modification in construction, change in occupancy or use, or structural repair to an existing building or facility. Alterations include, but are not limited to, remodeling, renovation, rehabilitation, reconstruction, historic restoration, resurfacing of circulation paths or vehicular ways, changes or rearrangement of the structural parts or elements, and changes or rearrangement in the plan configuration of walls and full-height partitions. Normal maintenance, reroofing, painting or wallpapering, or changes to mechanical or electrical systems are not alterations unless

~~they affect the usability of the building or facility~~ the repairs or alterations change the use of the building or structure.

...

Building Valuation. The total value of all construction work for which a building permit is issued, including, but not limited to, value of outside improvements, all finish work, painting, roofing, electrical, plumbing, heating, air conditioning, elevators, fire extinguishing systems, and any other permanently installed work or permanently installed equipment. ~~For projects consisting solely of repair, addition, or alterations of existing buildings, the building valuation shall be calculated as the total value of all design and construction costs for the project.~~

...

Deposit of Security. A financial security that can either be an automatically renewing Certificate of Deposit with the County or an automatically renewing irrevocable standby Letter of Credit payable to the County, in such format as specified by the County, in an amount equivalent to ~~one percent of the building valuation~~ the Eligible Project Value. The County, in its sole discretion, may provide additional forms of deposit for Developers to satisfy the Program Requirement.

...

Eligible Project. Residential development, or mixed use, commercial, or industrial development project, or any such project for repair, addition, or alterations of existing buildings in the unincorporated areas of the County with a building valuation of \$750,000 or greater; ~~or, any such project for repair, addition, or alterations of existing buildings with a design and construction project cost of \$750,000 or greater.~~ The

\$750,000 building valuation eligibility threshold shall be adjusted on ~~March 1, 2021~~July 1, 2023, and annually thereafter, based on the changes to the Consumer Price Index between March of the preceding year and March of the current year. The current building valuation threshold will be published on the Department of Arts and Culture website and/or available from the Public Art in Private Development Program Manager.

Eligible Project Value. The total value of the Public Art allocation based on one percent of the eligible building valuation of Eligible Projects.

In-Lieu Fee. An amount equal to ~~one percent of the building valuation~~ the Eligible Project Value paid into the Public Art in Private Development Fund, rather than providing Public Art pursuant to Section 22.46.090 E.1 (Establishment of Public Art in Private Development Program). Alternatively, if the Developer provides Public Art, pursuant to the same Subsection E.1, and the value of such Public Art is less than one percent of the building valuation, the In-Lieu Fee shall be the difference between one percent of the building valuation and the Public Art to be deposited into the Public Art in Private Development Fund.

...

SECTION 4. Section 22.20.030.C.2 is hereby amended to read as follows:

22.20.030 – Land Use Regulations for Zones C-H, C-1, C-2, C-3, C-M, C-MJ, and C-R.

...

C. Use Regulations

...

2. Accessory Uses. Table 22.20.030-C, below, identifies the permit or review required to establish each accessory use.

TABLE 22.20.030-C: ACCESSORY USE REGULATIONS FOR COMMERCIAL ZONES								
	C-H	C-1	C-2	C-3	C-M	C-MJ	C-R	Additional Regulations
...
Home-based occupations	P	P	P	P	P	P	P	<u>Section 22.140.290</u>
...

...

SECTION 5. Section 22.20.050 is hereby amended to read as follows:

22.20.050 – Development Standards for Zones C-H, C-1, C-2, C-3, and C-M.

A. Required Yards. Except as specified otherwise, Table 22.20.050-A, below, identifies the minimum yard depths for various development types in Zones C-H, C-1, C-2, C-3, and C-M as follows:

TABLE 22.20.050-A: MINIMUM YARD DEPTHS FOR COMMERCIAL ZONES						
Development Types	Zones	Front	Corner Side	Corner Side - Reversed Corner Lot	Interior Side	Rear
Non-residential	C-H and C-1	a) 20 feet where a lot fronts on a road classified as a			N/A	N/A

		major highway, secondary highway, or parkway; or b) equal to the front or corner side yard depth required on any contiguous Residential or Agricultural Zone where the property adjoins a street. ¹				
Residential	C-H, C-1, C-2 and C-3	15 feet	5 feet	7.5 feet	5 feet ²	15 feet
Mixed Use	C-H, C-1, C-2, C-3 and C-M	N/A	N/A	N/A	See Section 22.140.350.A.65.h	
Notes:						
1. Use the greatest distance if both apply.						
2. In Zone C-3, the minimum interior side yard depth is five feet where no building exceeds two stories in height, or five feet plus one foot for each story that exceeds two stories, except the maximum interior side yard depth is 16 feet.						

...

SECTION 6. Section 22.22.080 is hereby amended to read as follows:

22.22.080 – Development Standards for Zone M-2.5.

In Zone M-2.5, Conditional Use Permit (Chapter 22.158) applications shall be subject to the following additional procedures:

...

C. Covenant and Agreement. In addition to Section 22.222.260 (Performance Guarantees and Covenants), the applicant shall record in the Registrar-Recorder/County Clerk's Office, an instrument reading substantially as follows:

...

SECTION 7. Subsection 22.110.070 is hereby amended to read as follows:

22.110.070 – Fences and Walls.

...

B. Maximum Height of Fences and Walls. Fences and walls may be erected and maintained in required yards subject to the following requirements:

1. Front Yards. Fences and walls within a required front yard shall not exceed three and one-half feet in height. For example, see Figure 22.110.070-AB, ~~above~~ below.

2. Interior Side and Rear Yards. Fences and walls within a required interior side yard or rear yard shall not exceed six feet in height, provided that on the street or highway side of a corner lot such fence or wall shall be subject to the same requirements as for a corner side yard. For example, see Figure 22.110.070-B, ~~above~~ below.

3. Corner Side Yards. Fences and walls within a required corner side yard shall not exceed three and one-half feet in height where closer than five feet to the highway line, nor exceed six feet in height where located five feet or more from said highway line.

FIGURE 22.110.070-B: R-1 FENCE AND WALL HEIGHTS

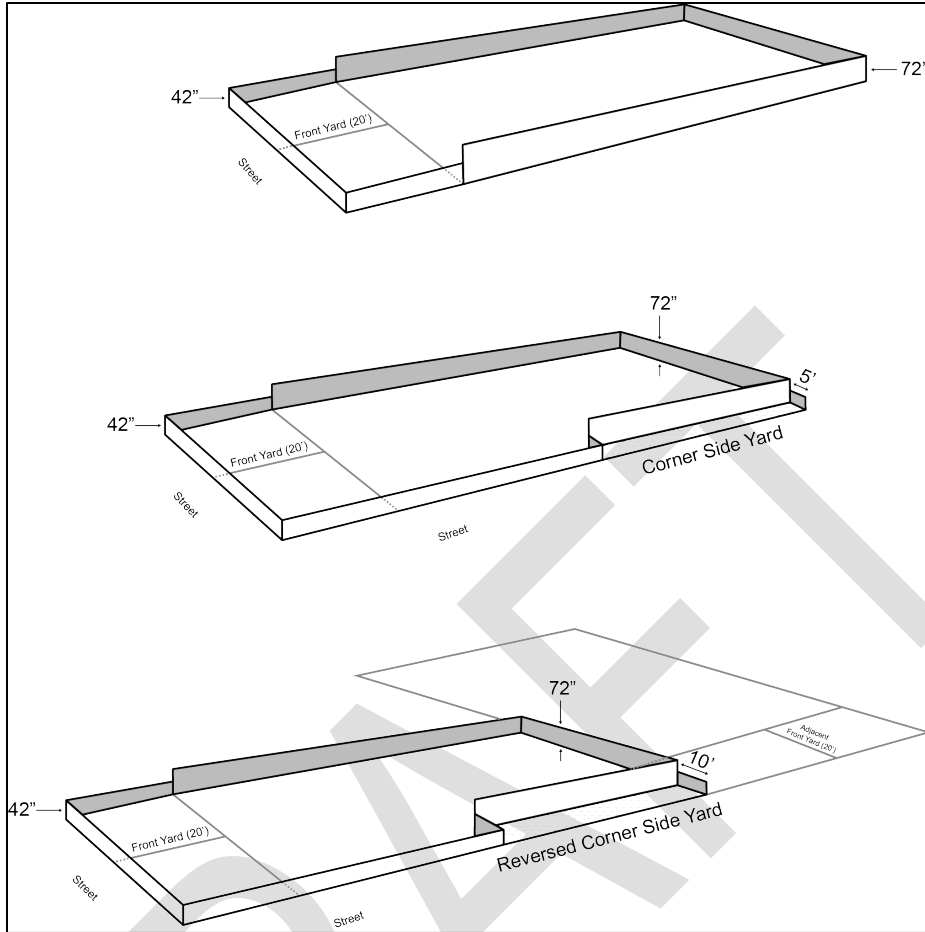

...

SECTION 8. Subsection 22.124.090 is hereby amended to read as follows:

22.124.090 – Process for Designation of a Landmark.

...

A. Review by the Director.

...

2. Report and Recommendation. Within 90 days of the date the Director mails the information required by Subsection A.1, above, but not sooner than the time

allowed for an owner to certify whether or not the owner consents to the landmark designation, the Director shall file a report with the Landmarks Commission containing:

...

The Director shall file a copy of the report with the Executive Officer-Clerk of the Board.

...

SECTION 9. Subsection 22.124.100 is hereby amended to read as follows:

22.124.100 – Process for Designation of a Historic District.

...

A. Review by the Director.

...

2. Report and Recommendation. Within 180 days of the date the Director mails the information required by Subsection A.1, above, but not sooner than the time allowed for an owner to certify whether or not the owner consents to the designation, including any extension granted by the Director, the Director shall file a report with the Landmarks Commission containing:

...

The Director shall file a copy of the report with the Executive Officer-Clerk of the Board.

...

SECTION 10. Subsection 22.140.290.B is hereby amended to read as follows:

22.140.290 – Home-Based Occupations.

...

B. Applicability. Applicability. This Section applies to home-based occupations in Zones A-1, A-2, R-A, R-1, R-2, R-3, R-4, R-5, C-H, C-1, C-2, C-3, C-M, C-MJ, C-RU, MXD-RU, and MXD.

...

SECTION 11. Section 22.140.350 is hereby amended to read as follows:

22.140.350 – Mixed Use Developments in Commercial Zones.

A. Mixed Use Development in Zones C-H, C-1, C-2, C-3, and C-M.

...

5. Development Standards. The following development standards shall apply:

a. Minimum Floor Area for Residential Use. At least two-thirds of the square footage of the mixed use development shall be designated for residential use.

For the purpose of this Subsection A.65.a:

...

SECTION 12. Section 22.140.430.C.3 is hereby amended to read as follows:

22.140.430 – Outdoor Storage.

...

C. Industrial Zones. This Subsection C applies to outdoor storage in Zones M-1, M-1.5, M-2, M-2.5, and M-3.

...

3. Modification of Fences or Walls.

a. Upon approval of a Minor Conditional Use Permit (Chapter 22.160) application, the Commission or Hearing Officer may modify fences or walls not open to view from any street or highway, or any area in a Residential, Agricultural or Commercial Zone:

i. Where adjoining property is located in an Industrial Zone and is developed with another outside storage use; or

ii. Where substantial fences, walls, or buildings are located adjacent to property lines on surrounding property which serve to enclose such yard as well or better than the wall or fence required herein.

~~b. Should the use, fence, wall, or building providing justification for such modification be removed, such wall or fence shall be provided in compliance with this Section within six months from the date of such removal. Upon approval of a Ministerial Site Plan Review (Chapter 22.186) application, the applicant may modify fences or walls not open to view from any street or highway, or any area in a Residential, Agricultural or Commercial Zone:~~

~~i. Where adjoining property is located in an Industrial Zone and is developed with another outside storage use; or~~

~~ii. Where substantial fences, walls, or buildings are located adjacent to property lines on surrounding property which serve to enclose such yard as well or better than the wall or fence required herein.~~

...

SECTION 13. Section 22.140.440 is hereby amended to read as follows:

22.140.440 – Parking as a Transitional Use.

...

B. Location. The lot to be used for transitional parking shall adjoin or be separated by an alley from a property with a qualifying zone. Qualifying zones include: C-1, C-2, C-3, C-M, CPD, C-RU, MXD-RU, M-1, M-1.5, MPD, M-2, M-2.5, M-3, B-1, and B-2.

...

SECTION 14. Section 22.140.550 is hereby amended to read as follows:

22.140.550 – Secondhand Stores.

...

B. Residential Uses Prohibited. A residential use, accessory or otherwise, is prohibited on the same lot as a secondhand store, unless the residential use is within a mixed use development that has a secondhand store and otherwise complies with Section 22.140.3650 (Mixed Use Developments in Commercial Zones).

...

SECTION 15. Section 22.140.580 is hereby amended to read as follows:

22.140.580 – Single-Family Residences.

...

F. Additional Standards for Zones C-RU and MXD-RU. In Zones C-RU and MXD-RU, the following additional standards shall apply:

...

3. The standards required by this Chapter shall not apply to any the commercial development on the same lot.

...

SECTION 16. Section 22.140.640 is hereby amended to read as follows:

22.140.610 – Wineries.

...

D. Application Requirements.

1. Ministerial Site Plan Review.

...

b. A Ministerial Site Plan Review (Chapter 22.186) application is required for wineries in Zones C-M, M-1, M-1.5, and M-2, unless Subsection D.3.eb, below, applies; or

...

SECTION 17. Section 22.166.050 is hereby amended to read as follows:

22.166.050 – Discretionary Housing Permit.

...

B. Findings and Decision.

...

2. Findings.

...

e. The project is ~~complimentary~~ complementary to the surrounding area in terms of land use patterns and design.

...

SECTION 18. Section 22.196.010 is hereby amended to read as follows:

22.196.010 – Applicability.

Yard Modifications, where authorized by Section 22.110.90809.E.3 (Yard Modification), Section 22.110.190 (Modifications Authorized) or as otherwise authorized by this Title 22, shall comply with this Chapter.

SECTION 19. Section 22.222.230 is hereby amended to read as follows:

22.222.230 – Effective Date of Decision and Appeals.

A. The Review Authority's decision shall be effective on the 15th day following the date of the decision, unless an appeal of the decision is ~~timely~~ filed before the effective date and the related appeal filing fee listed in Chapter 22.250 (Applications, Petitions, and Fees) is paid in full before the effective date, or an Appeal Body calls for review of the decision.

SECTION 20. Section 22.222.290 is hereby amended to read as follows:

22.222.290 – Bonds and Insurance.

A. Filing of Bonds.

1. Assignment of Savings and Loan Certificates Permitted When. If any provision of Chapter 22.162 (Development Agreements), Chapter 22.198 (Zone

Changes), or Section 22.06.060 (Zoned Districts Established) requires the filing of any bond as a prerequisite to any particular use of any property, the person making or proposing to make such use may, in lieu of such bond, deposit with the Executive Officer-Clerk of the Board and assign to the County, savings and loan certificates or shares equal in amount to the required amount of the bond. Such deposit and assignment shall comply with all of the provisions of Chapter 4.36 in Title 2 (Administrative Code) of the County Code.

...

B. Bonds or Assignment of Savings and Loan Certificates or Shares and Insurance.

...

3. Insurance Required When—Exceptions. The Board, Commission, or Hearing Officer may also require the owner of the property to which such approval applies to file a policy of insurance equal in amount to the amount of the required bond or deposit, insuring all persons against any injury or annoyance arising from the breach of such conditions unless:

...

b. If money, savings and loan certificates, or shares are deposited, such owners also file an agreement in writing with the Executive Officer-Clerk of the Board that the County may satisfy in whole or in part from such deposit any final judgment, the payment of which would have been guaranteed by such bond or policy of insurance.

SECTION 21. 22.234.020 is hereby amended to read as follows:

22.234.020 – Authority.

When the Director determines that the meaning or applicability of any provision of this Title 22 is subject to interpretation, the Director may issue a written interpretation, and may revise or withdraw a previously issued written interpretation when determined to be necessary to appropriately apply Title 22 under new circumstances.

SECTION 22. Section 22.240.030 is hereby amended to read as follows:

22.240.030 – Initiation of Appeals.

A. Filing. An appeal shall be filed with the secretary or clerk of the designated Appeal Body on the prescribed form before the effective date of the decision, along with any accompanying the related appeal filing fee listed in Chapter 22.250 (Applications, Petitions, and Fees) shall be paid in full before the effective date of the decision, and the prescribed form shall state specifically whether the basis of the appeal is that:

...

SECTION 23. Section 22.240.050 is hereby amended to read as follows:

22.240.050 – Fee for Appeals.

A. Processing Fee for Appeals to the Board.

...

2. Applicant Appeal of Conditions. If the appellant is the applicant or any representative thereof, and files an appeal of no more than a total of two conditions

of the approved discretionary permit, tentative map, or parcel map or request for waiver or other entitlement concurrently acted upon under Title 21 (Subdivisions) which concerns, in whole or in part, the same approved map, in any combination, the appellant shall pay a processing fee in an amount determined by the Executive Officer-Clerk of the Board to be ample to cover the cost of a hearing to be held by the Board. The appellant shall also pay a processing fee as listed in Chapter 22.250 (Applications, Petitions, and Fees) for an Appeal to the Board of Supervisors, Applicant for One or Two Project Conditions. This fee shall be applied to the Department to cover the costs of processing the appeal.

3. Non-Applicant Appeal. If the appellant is not the applicant or any representative thereof, of an approved discretionary permit, map, or waiver or associated entitlement, the appellant shall pay a processing fee in an amount determined by the Executive Officer-Clerk of the Board to be ample to cover the cost of a hearing to be held by the Board. The appellant shall also pay a processing fee as listed Chapter 22.250 (Applications, Petitions, and Fees) for an Appeal to the Board of Supervisors, Non-Applicant. This fee shall be applied to the Department to cover the costs of processing the appeal.

...

SECTION 24. Section 22.240.060 is hereby amended to read as follows:

22.240.060 – Procedures for Appeals and Calls for Review.

...

C. Plans and Materials.

1. At an appeal or review hearing, the Appeal Body shall consider the complete record, which includes but is not limited to:

i. ~~only~~The same application, plans, and materials that were the subject of the original decision;

ii. The record of the original decision, including transcripts of the proceedings, all notices and orders, any proposed decision by the Review Authority, the final decision by the Review Authority, all admitted exhibits, all rejected exhibits, and any other written evidence in possession of the Review Authority;

iii. Any additional staff reports and written comments received after the original decision and before the appeal or review hearing; and ~~Compliance with this provision shall be verified prior to or during the hearing by a representative of the person or body that made the original decision.~~

iv. If the matter was appealed more than once, the record of any subsequent decisions, including transcripts of the proceedings, all notices and orders, any proposed decisions, the final decisions, all admitted exhibits, all rejected exhibits, and any other written evidence in possession of the prior Appeal Body or Bodies.

2. If new plans and materials which differ substantially from the original are submitted, the applicant shall file a new application. A new application is not required if ~~C~~changes to the original submittal are made to meet ~~address~~ objections by the staff, objections by the Appeal Body, written comments received in opposition after the original decision and before the appeal or review hearing, and testimony or the opposition at the hearing ~~below need not be the subject of a new application.~~ As part of the decision, the

Appeal Body may impose additional conditions on a project in granting approval to a modified project.

D. Hearing. At the hearing, the Appeal Body shall review the complete record, ~~as described in subsection C.1, above, of the decision~~ and hear testimony of the appellant, the applicant, the party or body whose decision is being appealed or reviewed, and any other interested party.

E. Decision and Notice.

1. After the hearing, the Appeal Body shall affirm, modify, or reverse the original decision or refer the matter back for further review.

2. As part of the decision, the Appeal Body may impose additional conditions on a project in granting approval to a modified project.

3. When a decision is modified or reversed, the Appeal Body shall state the specific reasons for modification or reversal.

4. Decision on an appeal or review becomes final 30 days after the final findings and conditions have been adopted by the Appeal Body.

5. ~~4.~~ The secretary or clerk of the Appeal Body shall mail the notice of decision in compliance with Section 22.222.220 (Notice of Action), within 10 days after the date of the finalized decision.

~~F. Effective Date of Decision. Where the decision of the Appeal Body is final and the application is not subject to further administrative appeal, the date of decision by the Appeal Body on such appeal shall be deemed the date of grant in determining said expiration date.~~

~~G. Failure to Act. If the Appeal Body fails to act upon an appeal within the time limits prescribed in Subsection E.4, above, the decision from which the appeal was taken shall be deemed affirmed.~~

SECTION 25. Section 22.246.090 is hereby amended to read as follows:

22.246.090 – Public Art in Private Development Program.

...

C. Exemptions from Public Art in Private Development Program. The following shall be exempt from the provisions of this Section:

...

7. Repair or alterations of an existing building that are normal maintenance, reroofing, painting, or wallpapering, or changes to mechanical or electrical systems unless the repairs or alterations change the use of the building or structure.

8. Commercial and Industrial Development for use by a public entity for which the Board of Supervisors is the governing body.

...

F. Compliance with Public Art in Private Development Program.

...

3. For Public Art placed on the Developer's property, the Public Art is to be owned and maintained by the Developer or, if applicable, by occupants or owners of the subject property. Maintenance of the Public Art shall be adequately provided for in a covenant as approved by the Department of Arts and Culture, which shall run with the

land for a minimum of 25 years, unless a different timeframe is approved by the Department of Arts and Culture. If the nature of the Public Art requires other appropriate provisions to be made for the proper care and maintenance of the Public Art, in addition to or in lieu of a covenant, such additional or alternate provisions will be agreed to, pursuant to a form and standards as approved by the Department of Arts and Culture. Any Public Art to be removed, altered, or relocated from the subject property at any time shall be ~~deaccessioned~~ in accordance with the Policies and Procedures of the Department of Arts and Culture.

...

SECTION 26. Section 22.250.010 is hereby amended to read as follows:

22.250.010 – Filing Fees and Deposits.

...

C. Deposit Requirements for Selected Planning and Zoning Permits.

...

3. Final Fee Determination. The final fee for the zoning permits listed in this Subsection C shall be based on actual costs incurred by the Department to review and process all required zoning permit documentation.

...

d. Cost data used to determine planning and zoning permit fees shall be maintained, by the ~~planning business office~~ Department, and made available for public review while work is in progress and for three years following final action or withdrawal of the application.

...

SECTION 27. Section 22.250.040 is hereby amended to read as follows:

22.250.040 – eRecordation Fee.

A fee shall be added for in-house electronic recordings directly with the Los Angeles County Registrar Recorder/County Clerk's Office as requested by applicant, agent, and/or property owner as an added planning service to members of the public, as provided in Table 22.250.010-A, above.

SECTION 38. Section 22.262.040 is hereby amended to read as follows:

22.262.040 – Supplemental Fee Agreement.

A. Any supplemental service agreement entered into pursuant to this Chapter shall be negotiated by the ~~Department~~ and executed by the Department Chief Executive Officer.

B. The agreement shall include, but need not be limited to, substantially the following provisions:

...

4. The applicant shall deposit funds into a fund for that major project on a quarterly basis or as needed in an amount estimated to pay for the costs of providing the processing services for the following quarterly period.

5. The parties shall meet quarterly or as needed during the term of the agreement to review the amount of funds remaining in the fund and to review, reevaluate and negotiate in good faith the number and type of employees necessary to accomplish

the processing services for the next quarterly period and the estimated costs for the services.

...

SECTION 29. Division 10 of Title 22 is hereby repealed and replaced in its entirety to read as follows:

THIS SECTION 29 IS AVAILABLE SEPARATELY FOR REVIEW.

SECTION 30. Section 22.418.050 is hereby amended to read as follows:

22.418.050 – TOD Mixed Use Zones.

...

B. Land Use regulations for TOD Mixed Use Zones.

1. Allowed Uses. Table 22.418.050-A (TOD Mixed Use Zones Principal Use Regulations) prescribes the land use regulations for Zones MU-1, MU-2, MU-3, and MU-T. See Table 22.418.040-A (Permit and Review Requirements) for permit or review required to establish each use listed in Table 22.418.050-A (TOD Mixed Use Zones Principal Use Regulations).

...

Table 22.418.050-A: TOD MIXED USE ZONES PRINCIPAL USE REGULATIONS					
Use Category	MU_1	MU_2	MU_3	MU_T	Notes
...					
Residential Uses					
...					
Day Care*					
Adult day care centers*1	CUP	CUP	CUP	CUP	*Locational standards

Child care centers, less than 50 children* ¹	CUP	SPR	SPR	SPR	per Section 22.418.060.B
...					
Joint live and work units ² (one)	SPR	SPR	SPR	SPR	Section 22.140.320
...					
Notes: 1. <u>Locational standards per Section 22.418.060.B.</u> (4) 2. Two or more attached units required; use may also be subject to Chapter 22.120 (Density Bonus), Chapter 22.121 (Inclusionary Housing), or Chapter 22.166 (Housing Permits).					

C. Development Standards for TOD MU Mixed Use Zones.

...

Table 22.418.050-B: TOD MIXED USE ZONES DEVELOPMENT STANDARDS					
Use Category	MU-1	MU-2	MU-3	MU-T	Notes
...					

...

SECTION 31. Section 22.418.060 is hereby amended to read as follows:

22.418.060 – TOD Residential Zones.

A. Purpose. The general purpose of the TOD Residential Zoning Districts (Residential Zones), as established by the FFTOD Specific Plan and shown in Figure 22.418.060-1 (TOD Residential Zones), is to support a variety of housing options, types, configurations, and affordability levels within proximity to transit.

...

B. Land Use Regulations for TOD Residential Zones.

1. Allowed Uses.

a. Table 22.418.060-A (TOD Residential Zones Principal Use Regulations) prescribes the land use regulations for the Specific Plan TOD Residential Zones (RSS, RM, RLM-2, RLM-1). Table 22.418.040-A (~~R Zone Principal Use Regulations~~ Permit and Review Requirements) lists the type of review required to establish various land uses.

...

2. Allowed non-residential uses, per Table 22.418.060-A (TOD Residential Zones Principal Use Regulations), are intended to provide in-neighborhood daily services or needs such as small independent grocers or personal services. All non-residential uses shall be:

...

3. Accessory Uses. Accessory uses for TOD Residential Zones RLM-1, RLM-2, RM, and RSS shall be regulated by Table 22.18.030-C (Accessory Use Regulations For Residential Zones), pursuant to accessory uses listed for Zones R-2, R-3, R-4, and R-5, respectively.

4. Temporary Uses. Temporary uses for TOD Residential Zones RLM-1, RLM-2, RM and RSS shall be regulated by Table 22.18.030-D (Temporary Use Regulations For Residential Zones), pursuant to temporary uses listed for Zones R-2, R-3, R-4, and R-5, respectively.

...

TABLE 22.418.060-A: TOD <u>RESIDENTIAL</u> ZONES PRINCIPAL USE REGULATIONS					
Use Category	RLM-1	RLM-2	RM	RSS	Notes
Agricultural and Resource-Based Uses					

Community gardens	P	P	P	P	
Secondary land uses under high-voltage transmission lines	SPR	SPR	SPR	SPR	Section 22.140.630
Cannabis Uses					
Cannabis cultivation, personal, accessory to a legally established dwelling unit	P	P	P	P	
Cultural, Educational, and Institutional Uses*					
Churches, temples, or other places used exclusively for religious worship, including accessory educational and social activities	CUP	CUP	CUP	CUP	Accessory uses subject to the permissions of this table
Community centers* ¹	CUP	CUP	CUP	CUP	*Locational standards per Section 22.418.060.B
Libraries* ¹	CUP	CUP	CUP	CUP	
Museums* ¹	-	-	CUP	CUP	
...

Residential Uses					
...
Multi-family housing					
Multi-family, all configurations consistent with development standards	<u>PSPR</u>	<u>PSPR</u>	<u>PSPR</u>	<u>PSPR</u>	
Two-family residences	SPR	<u>-SPR</u>	-	-	
Residential Substance Use Recovery					
...
Single-family residences	<u>PSPR</u>	-	-	-	Section 22.140.580
...
Day care*					
Adult day care centers* ¹	CUP	CUP	CUP	CUP	*Locational standards per Section 22.418.060.B
Child care centers, less than 50 children* ¹	CUP	SPR	SPR	SPR	
...

Retail/Commercial/Service Uses*					
Alcohol beverage sales, for on-site consumption* ¹	CUP	CUP	CUP	CUP	Section 22.140.030 *Locational standards per Section 22.418.060.B
Alcoholic beverage sales, for off-site consumption* ¹	CUP	CUP	CUP	CUP	
Art galleries* ¹					*Locational standards per Section 22.418.060.B
Bakery shops (full service or accessory to retail)* ¹	SPR	SPR	SPR	SPR	
Barber / Beauty / Spa services and shops* ¹	SPR	SPR	SPR	SPR	
Drugstores* ¹	SPR	SPR	SPR	SPR	
Farmers' markets	P	P	P	P	
Food Service (cafes, delicatessens, ice cream shops, etc.)* ¹	SPR	SPR	SPR	SPR	
Grocery / food stores* ¹	SPR	SPR	SPR	SPR	

Medical and Dental clinics, excluding laboratories* ¹	SPR	SPR	SPR	SPR	
Offices, business or professional* ¹	SPR	SPR	SPR	SPR	
Retail services (florist shops, newsstands, etc.)* ¹	SPR	SPR	SPR	SPR	
Retail store / sales* ¹	SPR	SPR	SPR	SPR	
Transportation, Electrical, Gas, Communications, Utilities, and Public Service Uses					
...
<u>Notes:</u>					
1. Locational standards per Section 22.418.060.B.					

C. Development Standards for TOD Residential Zones.

1. Standards. All structures and uses in the TOD Residential Zones (RSS, RM, RLM-2, RLM-1) shall be subject to the regulations of Table 22.418.060-B (Residential Zones Development Standards), with the exception of single-family residences on compact lots, which shall be subject to Section 22.140.585 (Single-Family Residences on Compact Lots) consistent with Zone R-4 standards.

...

TABLE 22.418.060-B: <u>TOD</u> <u>RESIDENTIAL</u> <u>ZONES</u> <u>DEVELOPMENT</u> <u>STANDARDS</u>					
Standard	RLM -1	RLM-2	RM	RSS	Notes
...					

TABLE 22.418.060-B: <u>TOD</u> RESIDENTIAL ZONES DEVELOPMENT STANDARDS					
Standard	RLM -1	RLM-2	RM	RSS	Notes
3. Minimum Setbacks (22.418.090.F) Measured from Property Line (PL) unless otherwise noted					
...					
Alley Setback, garage	3' or ≥ 18'; driveway widths <u>depths</u> of 3' < 18' are prohibited				
Parking/Garage Alley Setbacks	3' for shared garage access; 3' or ≥ 18' for individual unit garages; driveway widths <u>depths</u> of 3' < 18' are prohibited				
...					

SECTION 32. Section 22.418.100 is hereby amended to read as follows:

22.418.100 – Circulation and Parking Standards.

A. Required Parking by Use or Zone. Except where prohibited by State law, the standards for parking requirements contained in Chapter 22.112 (Parking) shall apply to all development in the Specific Plan Area with the following modifications. Reductions are intended to provide parking supply that supports TOD development and allows for greater flexibility in design and multi-modal access.

...

3. Residential Requirements. All residential uses in the RM, RSS, and MU zones shall provide the minimum required parking consistent with Table 22.418.100-B (Minimum Parking by Residential Unit Type); this modifies Chapter 22.112 (Parking) requirements for residential units.

...

TABLE 22.418.100-B: MINIMUM PARKING BY RESIDENTIAL UNIT TYPE		
Unit Type*	Number of Spaces	Standard/Exceptions
Bachelor	0.75 space/unit	Unbundling required in TOD MU zones and allowed in Residential Zones
Efficiency/One-Bedroom	1 space/unit	
≥ Two Bedrooms	1.25 space/unit	
Guest Parking (all unit types)	1 space/10 units	Only required for projects with 10 or more units in any zone

...

DRAFT